

RAVAS-2100

A PALLET TRUCK SCALE FROM
THE LEADER IN MOBILE
WEIGHING

RAISES EFFICIENCY AND SIMPLIFIES LOGISTIC
PROCESSES, SAVES TIME AND SPACE

FOR CHECKING INCOMING GOODS, FILLING
CONTAINERS AND BIG BAGS, DETERMINING
SHIPPING WEIGHTS, AVOIDING OVERLOADS

HIGH ACCURACY: MAXIMUM ERROR 0.1% OF
THE APPLIED WEIGHT

ERGONOMIC DESIGN: LEVER FUNCTIONS WHICH
CAN BE OPERATED RIGHT OR LEFT-HANDED;
WEIGHS ONLY 99 KG

EASILY EXCHANGEABLE BATTERY PACK FOR
CONTINUOUS USE; CHARGER INCLUDED

LOW POWER CONSUMPTION; AUTOMATIC
SWITCH-OFF



FUNCTIONS

- ◆ Automatic and manual zero correction
- ◆ Gross/net weighing
- ◆ Automatic and manual tare up to 200 kg
- ◆ Totalling with sequence number
- ◆ Error messages in display
- ◆ Automatic switch-off after 30 minutes of non-use
- ◆ Low battery indication 5 hours before battery is empty



Exchangeable battery module

RAVAS

DIMENSIONS

A	Fork length	:	1150 mm
B	Fork width	:	170 mm
C	Minimum fork height	:	85 mm
	Minimum space between floor and forks	:	22 mm
D	Maximum fork height	:	205 mm
	Lifting height	:	120 mm
E	Width over forks	:	540 mm
F	Height to top indicator	:	770 mm

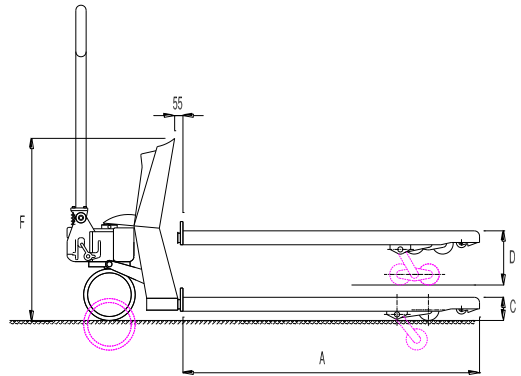

PRECISION STANDARD VERSION

Max. inaccuracy : 0.1% of the applied weight

Graduation : multirange
 0 - 200 kg: graduation 0.2 kg
 200 - 500 kg: graduation 0.5 kg
 500 - 2200 kg: graduation 1 kg

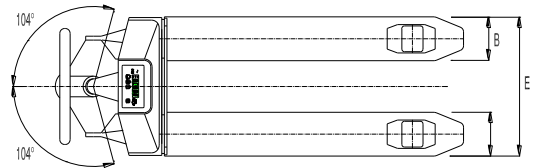

PRECISION APPROVED FOR TRADE VERSION CLASS III

Multirange or options possible:

- 1000 divisions : 1.0/1000 kg or 2.0/2000 kg
 - 2000 divisions : 0.5/1000 kg or 1.0/2000 kg
 - 3000 divisions : 0.1/300 kg or 0.2/600 kg or 0.5/1500 kg

STANDARD SPECIFICATIONS

Weighing capacity : 2200 kg
 Display : LCD, height 18 mm
 Keypad : 3 function keys, on / off key
 Protection class : load cells and cabling IP67, indicator IP65
 Steering wheels : rubber
 Loading wheels : polyurethane, single
 Colour : red (RAL 3000), epoxy painted
 Own weight : 99 kg
 Battery : 12 Vdc / 1.2 Ah, exchangeable; delivery including separate charging module
 Battery life : 35 hours
 low battery indication 5 hours before automatic switch-off
 Charger : 230 Volt / 12 Vdc - 300 mA
 Charging time : approximately 6 hours
 Pump : quick lift
 For approved versions class III : European approval no. T2782
 switch-off of display when tilting more than 2°



OPTIONS WEIGHING SYSTEM *

Approved version : legal for trade OIML class III
 Smaller graduation : finer multirange 0.1 / 0.2 / 0.5 kg (with reduced weighing capacity)
 RS232 output : for data communication (e.g. with printer)
 Built-in printer : thermal or matrix; for printing weighing data on-site
 Push buttons : for easy operation when wearing gloves
 Pivoting indicator : plastic or metal enclosure for reading display from all angles
 Extra exchangeable battery : for continuous use
 Explosion proof version : EXi, ATEX certified

OPTIONS HAND PALLET TRUCK *

- Stainless steel version
- Stainless steel fork shoes
- Galvanised version
- Recess frame
- Steering wheels in polyurethane or nylon
- Loading wheels in nylon and/or tandem
- Handbrake
- Footbrake
- Capacity 3000 kg (graduation 1 kg)
- Fork length from 950 mm to 2400 mm
- Width over forks 700 mm and special widths

* For special options the specifications can differ from standard specifications



RAVAS

RAVAS Europe B.V.

P.O. Box 2023
 NL-5300 CA Zaltbommel
 The Netherlands

+31 – (0) 418 - 51 52 20

+31 – (0) 418 - 51 53 20

info@ravas.com

www.ravas.com

Rev.30.09.08

Changes reserved